



**FLEXAHOPPER PLASTICS LTD**

COMMITTED TO

# OIL & GAS.

---

For over 50 years Flexahopper has manufactured reliable and premium quality products to ensure that the **strictest safety standards** in the Oil & Gas Industry are met. We take pride in our reputation and **clean record for no spill or leakage in the field.**

Our commitment to excellence combined with customer input has helped us develop the most innovative and durable products in the industry.



# YOUR OIL & GAS SPECIALIST.

---

Flexahopper Plastics is a 100% Canadian owned and operated rotational molding plastics company founded in 1967 and headquartered in Lethbridge, AB.

Flexahopper Plastics is committed to world-class customer service, strong quality control, and continues to invest in advanced processing technologies. Through membership in many professional and trade associations such as ARM (Association of Rotational Molders), as well as extensive research and development, we are successful in taking many complex and difficult to produce products to market.

It takes more than just high-grade materials to produce a quality product. That's why, here at Flexahopper Plastics, our resources include cutting edge technology and expert service to assure complete customer satisfaction.

**Our commitment to quality is the link between our products and your safety.**



## FEATURES (FOR ALL CHEMICAL STORAGE TANKS)

Corrosion and chemical resistant

Rugged impact resistant polyethylene

Outstanding resistance against deterioration from Ultra-Violet light

One piece seamless construction

Comes standard with vented lid and outlet fitting

Semi-transparent for level indication

Repairable polyethylene

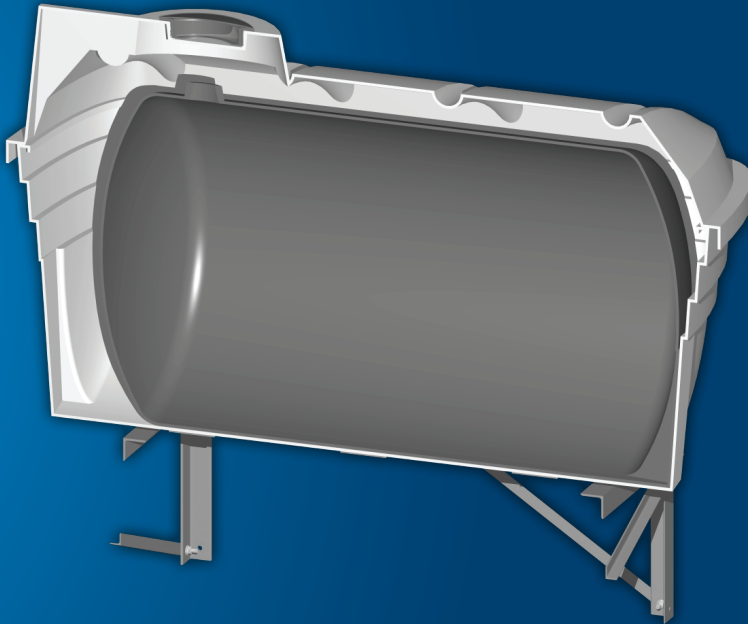

## DOUBLE WALL TANKS

MODEL



length x width x height  
inches



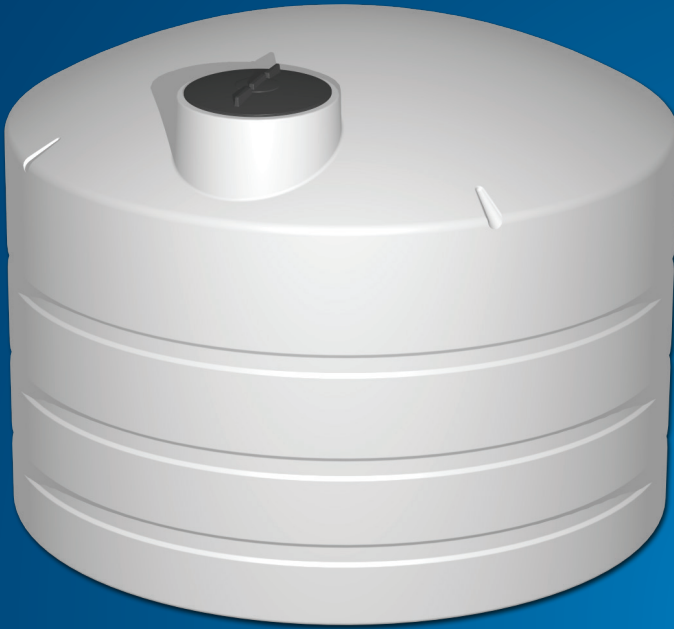

Imp. Gal. / Litres / US Gal.

DW 50	37" x 14 7/8" x 53"	53	240	64
DW 100	62 5/8" x 39 3/8" x 35 3/8"	100	455	120
DW 120	34 1/4" x 66"	120	546	144
DW 500	96 23/32" x 63" x 64 17/32"	500	2273	600



## VERTICAL CYLINDRICAL TANKS (VCT)

MODEL	 width x height inches	 Imp. Gal. / Litres / US Gal.
VCT 120	30" x 50"	120 546 144
VCT 180	30" x 80"	180 818 216
VCT 200	31" x 77"	200 909 240
VCT 300	36" x 86"	300 1364 360
VCT 500	59" x 66"	500 2273 600
VCT 500N	49" x 84"	525 2387 630
VCT 750N	49" x 114"	750 3410 901
VCT 840	66" x 74"	840 3819 1009
VCT 850	87" x 48"	898 4082 1078
VCT 900	59" x 106"	900 4091 1081
VCT 925N	49" x 142"	911 4141 1094
VCT 1250	87" x 64"	1250 5683 1501
VCT 1275	66" x 112"	1295 5887 1555
VCT 1300	75" x 88"	1300 5910 1561
VCT 1550	87" x 80"	1550 7046 1861
VCT 1700	66" x 149"	1700 7728 2042
VCT 2000	97" x 94"	2000 9092 2402
VCT 2200	87" x 105"	2200 10001 2642
VCT 2600	90" x 132"	2600 11820 3122
VCT 3150	97" x 144"	3150 14320 3783
VCT 4300	120" x 118"	4300 19548 5164
VCT 5700	120" x 152"	5700 25913 6845

## FEATURES (FOR ALL CONTAINMENT VESSELS)

Durable and rugged design for reliable, environmental liquid containment.

Easy handling and shipping. Highly portable for relocation to other well heads.

UV absorbing design to enhance evaporation and internal graduations for liquid monitoring.

Drop in internal liner also available where secondary containment is required.

Static Eliminator System (SES™) standard.

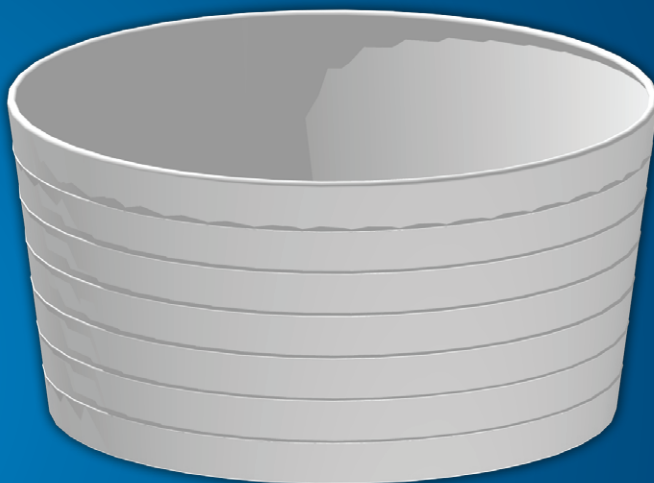

## OPEN TOP TANKS (OT) DOG DISHES™

MODEL  diameter x height  
inches  Imp. Gal. / Litres / US Gal.

TAPER 100	24 1/3" x 50 1/2"	100	455	120
TAPER 275	41 9/16" x 54 1/4"	275	1250	330
OT 500	58" x 58 1/2"	500	2273	600
OT 850	87" x 38 1/2"	850	3864	1021
OT 858	87" x 52 1/4"	858	3901	1030
OT 1100	87" x 52"	1100	5001	1321
OT 1050	92 1/8" x 44 3/8"	1050	4773	1261
OT 1400	87" x 67 1/2"	1400	6365	1681
OT 1640	91" x 66 1/4"	1640	7456	1970
OT 2000	96" x 74"	2000	9092	2402
OT 2050	87" x 92"	2050	9319	2462
OT 2450	87" x 115"	2450	11138	2942
OT 3500	143" x 71 1/2"	3500	15911	4203
OT 5000	178 5/8" x 71"	5000	22730	6005
OT 5500	176" x 68"	5500	25004	6605

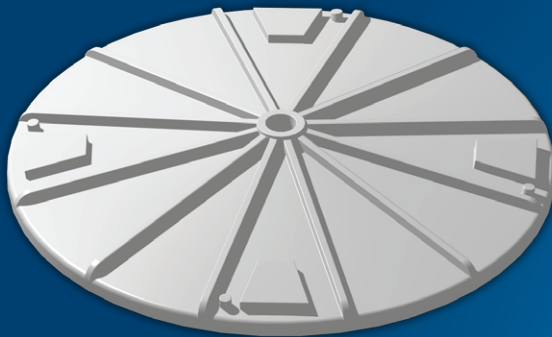

## OPEN TOP TANK LIDS

MODEL



diameter  
inches

14' 9 1/2" Lid	14' 9 1/2" Dia - 5500 OT Lid
94" Lid	93" Dia - 1050 & 1640 OT Lid
90" Lid	90" Dia - 1100 & 1400 OT Lid



## LINERS

MODEL



length x width x height  
inches



Imp. Gal. / Litres / US Gal.

Liner 858	52 1/4" H x 75 1/4" Dia	858	3900	1030
Liner 1050	44 3/8" H x 88 3/8" Dia	1050	4773	1261
Liner 1640	66 1/4" H x 91" Dia	1640	7462	1971
Liner 5000	71" H x 178 5/8" Dia	5000	22730	6000



## FEATURES (FOR ALL SPILL TRAYS)

Durable and rugged design for reliable, environmental liquid containment.

UV absorbing design to enhance evaporation.

Easy handling and shipping.

Highly portable for relocation to other well heads.

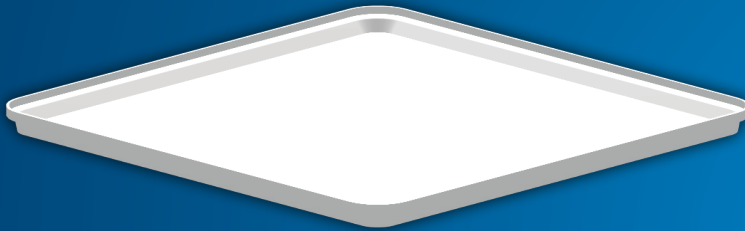

## SPILL TRAYS

MODEL

length x height x width  
inches

Imp. Gal. / Litres / US Gal.

1 Gal	35" x 3/4" x 11"	1.3	6	1.5
2 Gal	35" x 3/4" x 17"	2	9	2.4
2.5 Gal	35" x 3/4" x 23"	2.6	12	3
3 Gal	35" x 3/4" x 35"	3	14	3.7
14 Gal	70" x 2" x 33"	14	64	17
16 Gal	51" x 2 1/2" x 51"	16	73	19
50 Gal	49 1/2" x 7" x 49 1/2"	61	280	73
80 Gal	100" x 2" x 54 3/4"	80	364	96
100 Gal	71" x 10" x 46"	115	525	138
109 Gal	90" x 7" x 56"	109	496	131
275 Gal	64" x 25" x 64"	275	1250	330
575 Gal	103" x 22 3/4" x 92 1/2"	575	2614	691
950 Gal	120" x 19 1/4" x 120"	950	4319	1141
1250 Gal	170" x 24" x 99"	1250	5862	1500



## FEATURES (FOR ALL WASTE HANDLING CONTAINERS)

High durability for years of trouble free performance.

Foam Filled which allows 30 lbs per square inch in loading capacity.

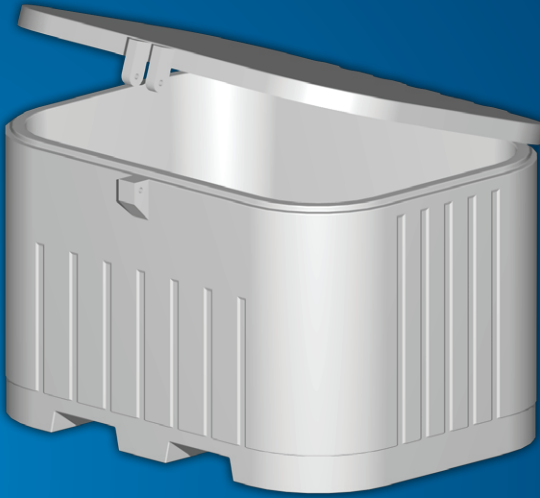

## WASTE HANDLING

MODEL



length x height x width  
inches



Imp. Gal. / Litres / US Gal.

Battery Box 22 w / lid	48 1/4" x 40 1/4" x 29 3/4"	137	622	164
Battery Box 22.5 w / lid	48 3/4" x 43 1/2" x 34"	140	638	168
1 cubic meter bin	48 1/2" x 40" x 43 1/4"	193	880	232
3 cubic meter bin	84 1/4" x 49 3/4" x 62"	616	2800	740



## PIPE STANDS

MODEL



height x width  
inches

21" Pipe Stand

21" x 24"





**FLEXAHOPPER PLASTICS LTD**



100% Canadian owned company.



Since 2007 Flexahopper has demonstrated a strong commitment with the environment by using green energy that comes from wind and water sources across Canada.

---

**BECAUSE GREEN MATTERS AND  
IT IS THE RIGHT THING TO DO.**

## CONTACT US

---

Headquarters

2530 - 39 STREET NORTH, LETHBRIDGE, AB T1H 5J2

Toll Free **1.888.328.8176**

Web Site **WWW.FLEXAHOPPER.COM**

Telephone **1.403.328.8146**

Email **AGRICULTURE@FLEXAHOPPER.COM**

Fax **1.403.328.8476**

# CONTACT.

---

Headquarters

2530 - 39 STREET NORTH, LETHBRIDGE, AB T1H 5J2

Toll Free 1.888.328.8176

Web Site

[WWW.FLEXAHOPPER.COM](http://WWW.FLEXAHOPPER.COM)

Telephone 1.403.328.8146

Email

[AGRICULTURE@FLEXAHOPPER.COM](mailto:AGRICULTURE@FLEXAHOPPER.COM)

Fax 1.403.328.8476

